

Slip rings

Modular	Fieldbus – 100 Mbit/s	SR120
----------------	------------------------------	--------------



In general slip rings are used to transmit power, signals or data, pneumatic and hydraulic, from a stationary to a rotating platform.

The transmission between the stator and rotor takes place via sliding contacts and is extremely reliable.

The slip ring SR120 is ideal for applications requiring high transmission rates. The three chamber system allows parallel transmission of signals, load and data up to 100 Mbit/s.



Rugged

- Reliable operation in harsh environments.
- Rugged metal housing.
- High protection level IP64.

Flexible

- Fast and easy installation.
- Modular construction.
- Wide variety of connector and cable connections.

Reliable with the three chamber system

- Reliable thanks to interference-proof transmission.
- Transmission of Ethernet, signal, load, pneumatics and hydraulics.
- Innovative contact technology, low-maintenance and durable.
- Fieldbus or Ethernet up to 100 Mbit/s.

Application areas for slip rings

Industrial automation, bottling plants, labelling machines, rotary tables, ...

Order code

for standard versions

SR120 Type	- XX -	- XX -	- XX -	- XX -	- X0X2 -	V100
	a	b	c	d	e f g h	i

a Type of mounting

- 01 = flange mounting, rotor connections radial
- 02 = flange mounting, rotor connections axial

b Module fieldbus transmission

- 00 = none
- 01 = fieldbus transmission up to 100 Mbit/s (others on request)

c Number of signal / data channels (0, 2, 4, 6, 8, 10)

- 00 = no signal / data channel
- 02 = 2 signal / data channels
- ...
- 10 = 10 signal / data channels (others on request)

d Number of load channels

- 00 = none
- 02 = 2 load
- 04 = 4 load
- 06 = 6 load
- L3 = 3 load + ground PE
- L4 = 4 load + ground PE (others on request)

e Load channels max. load current

- 0 = none
- 1 = 16 A, 240 V AC/DC
- 2 = 25 A, 240 V AC/DC
- 3 = 10 A, 400 V AC/DC
- 4 = 20 A, 400 V AC/DC

f Type of connection

- 0 = cable ¹⁾

g Media rotary feedthrough

- 0 = none
- A = central bore, inside diameter 20 mm
- C = air, rotatable connector
- Flange mounting** for 12 mm tube (others on request)

h Protection rating

- 2 = IP64

i Version number (options)

- V100 = standard

1) Except Ethernet channel (M12 connector).

Slip rings

Modular	Fieldbus – 100 Mbit/s	SR120
Cables and connectors		Order no.
Preassembled cables	M12 male connector with external thread, 4-pin, straight 2 m [6.56'] PUR cable	05.00.6031.4411.002M
Connectors	M12 male connector with external thread, 4-pin, straight	05.WASCSY4S

Further Kübler cables and connectors can be found at: kuebler.com/connection-technology

Technical data	
Overall length	dep. on the number of transmission paths
Type of connection (stator and rotor)	load cable 2 m [6.56'] signal / data cable 2 m [6.56'] Ethernet M12 connector 4-pin, D coded
Material pairing	load copper / brass signal / data silver / precious metal Ethernet silver / precious metal
Voltage/current loading	load channels max. 10 A, 400 V AC/DC max. 16 A, 240 V AC/DC max. 25 A, 240 V AC/DC max. 20 A, 400 V AC/DC signal channels max. 2 A, 48 V AC/DC
Contact resistance	load channels $\leq 1 \text{ Ohm}$ (dynamic) ¹⁾ signal / data channels $\leq 0.1 \text{ Ohm}$ (silver / precious metal) ²⁾
Insulation resistance	10^3 MOhm , at 500 V DC
Dialectric strength	1000 V eff. (60 sec.)
Speed max. (signal / data channels)	300 min^{-1} (depends on installation position and numbers of channels)
Service life (signal / data channels)	typ. 500 million revolutions ³⁾ (at room temperature) depends on installation position
Maintenance cycles	maintenance free (if necessary all 100 million revolutions)
Operating temperature	-35 °C ... +85 °C [-31 °F ... +185 °F]
Protection acc. to EN 60529	max. IP64

Approvals	
CE compliant in accordance with Low Voltage Directive	2014/35/EU
UKCA compliant in accordance with Low Voltage Regulations	S.I. 2016/1101

1) Voltage measurement, ambient temperature, DC series connection, ohmic load, min. 4 A test current.

2) 2-wire resistance measurement, ambient temperature, 6.5-digit digital multimeter or similar, values without testing cable.

3) Typical values, may vary considerably depending on installation situation and application.

Slip rings

Modular	Fieldbus – 100 Mbit/s	SR120
----------------	------------------------------	--------------

Terminal assignment

M12 connector, 4-pin					
Signal:	Transmit data +	Receive data +	Transmit data -	Receive data -	
Abbreviation:	TxD+	RxD+	TxD-	RxD-	
Pin:	1	2	3	4	

Dimensions

Dimensions in mm [inch]

Standard version

Example: Type SR120-02-01-02-03-2002-V100

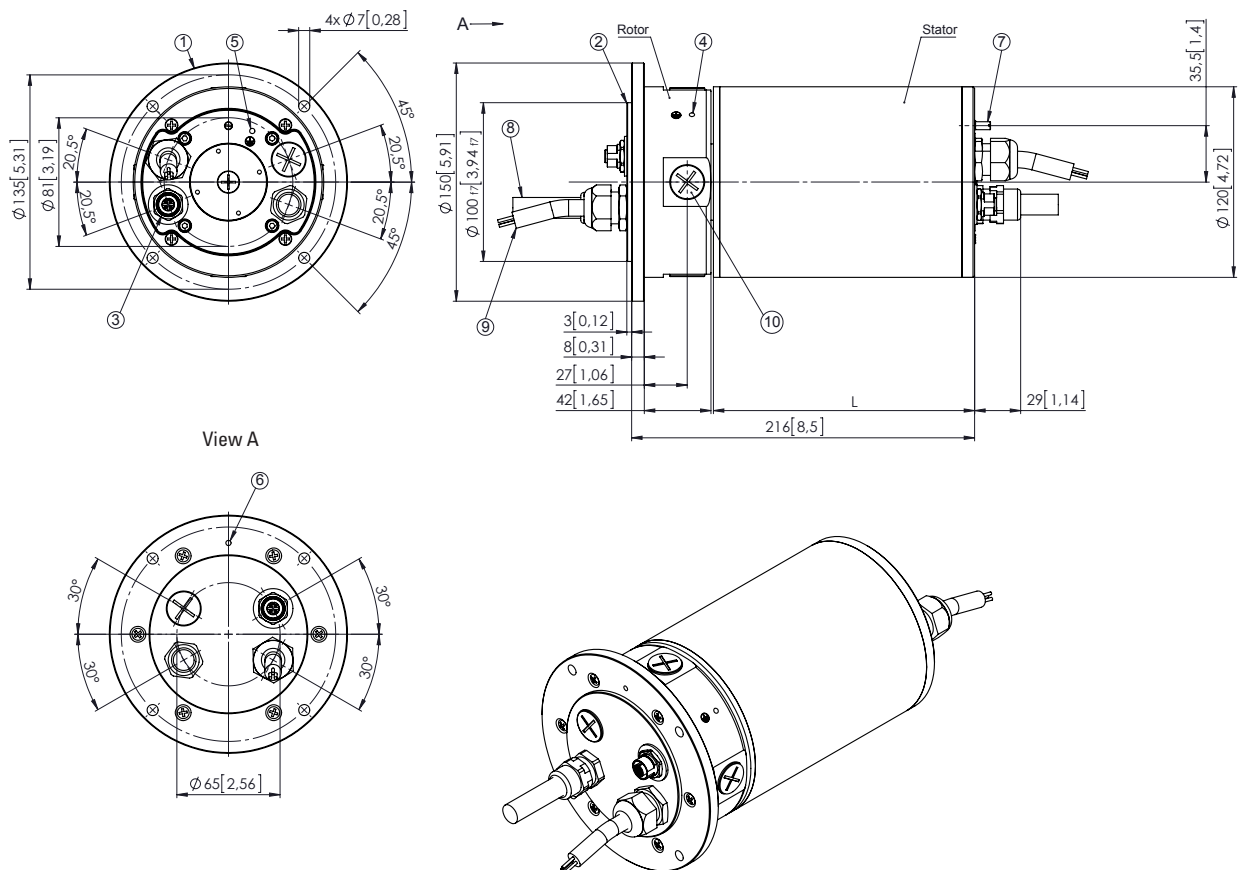

- | | | |
|--|---------------------------------------|---|
| 1 – Mounting flange | 4 – Ground PE (optional connectivity) | 8 – 2 m [6.56'] connecting cable for load transmission |
| 2 – Centering diameter | 5 – Ground PE (optional connectivity) | 9 – 2 m [6.56'] connecting cable for signal transmission |
| 3 – M12 female connector (4-pin)
Ethernet (data transmission) (D-coded) | 6 – Ground PE (optional connectivity) | 10 – Blind plug – depending on order code rotor
connections exit axially |
| | 7 – Anti-rotating-pin | |